



Rittal **outdoor enclosures and outdoor climate control components** will withstand even the toughest wind and weather conditions. In this respect, we are uncompromising.

From basic requirements such as humidity, temperature fluctuations and sunlight, to **extreme conditions** such as seawater resistance or earthquake resistance, through to protection against vandalism, Rittal has the answer.

In this way, we ensure that there are no limits to our customers' applications.



# Communication Systems

---

## **CS Outdoor enclosures** **from page 872**

Features ..... 872

---

## **CS modular enclosures** **from page 874**

CS modular enclosures ..... 874  
Installation variants, width 600 mm ..... 875  
Installation variants, width 800/1200 mm ..... 876

---

## **Toptec CR** **from page 877**

---

## **CS Basic enclosures** **from page 878**

Single-door, width 600 mm ..... 878  
Single-door, width 800 mm ..... 879  
Two-door, width 1200 mm ..... 880

---

## **CS wall-mounted enclosures** **from page 881**

---

## **Outdoor climate control** **from page 882**

Features ..... 882

---

## **Cooling units for CS modular enclosures** **from page 883**

---

## **Heat exchangers for CS modular enclosures** **from page 884**

---

## **Climate control units for Toptec CR** **from page 886**

---

## **Geothermal heat exchanger, Terravent** **from page 887**

---

## **CS fuel cell** **from page 888**

Features ..... 888  
Fuel cell 3 and 5 kW ..... 889

# CS Outdoor enclosures

## Features



For all requirements in the outdoor sector, Rittal has the ideal enclosure solution, thanks to its platform strategy.

With single-walled or twin-walled enclosures of aluminium or coated sheet steel, as well as an extensive range of accessories. With constant interior temperatures and perfect climate, thanks to in-house development and production of cooling units, heat exchangers and heaters.

CS Outdoor enclosures

### CS modular enclosures



**Protection against vandalism** – These features will protect your equipment against unauthorised access: **No point of access for lever-type tools**, because the double side panel seamlessly conceals the door hinges.

The hinged **roof is screw-fastened to the enclosure body**.

The **base/plinth trim is secured with safety screws**.



Batteries for emergency power back-up are securely housed in the **pull-out drawer** of the battery base/plinth.

**High level of stability** thanks to **ten-fold profiling** of the enclosure body.

Rittal accessory components facilitate fast, **universal interior installation**.

### CS wall-mounted enclosures



The **enclosure-within-an-enclosure concept** with the curved designer cover is a characteristic feature.

**Security lock** on the designer cover and door of the interior enclosure.

**Air louvres** at the sides and in the rear panel.

B  
6.1



### Toptec CR



**Functional design**  
No roof projection at the sides – enclosures are connected via cut-outs or by buying complete enclosures.

**Enclosure platform TS 8**  
TS 8 vertical sections and system punchings are the key to the comprehensive range of accessories.

**Climate control modules**  
Climate control – identical door cut-outs for cooling units and air/air heat exchangers offer variability when selecting climate control components.



**Twin-walled doors**  
Chimney effect – The twin wall minimises the influence of sunlight and prevents condensation.

**Multifunctional rain canopy**  
protects the side panel from removal, while ventilation prevents condensation and the sloping roof stops rainwater from accumulating.

**Lock system**  
The doors at the front and rear each have one swing lever handle with security lock.



### CS basic enclosures



**Eyebolts**, concealed by the rain canopy, for crane transportation of the fully fitted unit.

**Ventilation louvres** all-round in the hinged rain canopy – with an all-round roof projection of 25 mm.

Width 1200 mm: **With removable centre bar** and two lockable doors with or without centre bar, with overlapping doors.



The open base frame may be covered with **gland plates**.

Individual installation with an **extensive choice of system accessories**.

**25 mm system punchings** for mounting 482.6 mm (19") mounting angles, mounting plates or partial mounting plates.

# CS modular enclosures

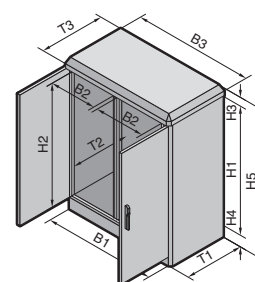
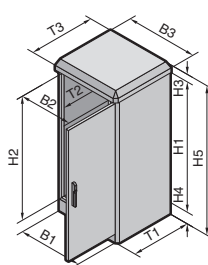

## Technical specifications:

Basic module:  
Solid top and sides, closed base with 4 gland plates (width 600 mm with 2 gland plates).  
Double-walled rear panel screw-fastened from the inside.  
Double-walled door with Ergo-form padlock handle with 3-point locking, foamed-in PU seal.  
Gas pressurised spring as door stay.  
Double side panel across the enclosure and base/plinth, screw-fastened from the inside, screws not visible from the outside.

Rain canopy, 75 mm high, hinged, 25 mm projection on all sides.  
Base/plinth, 100 mm high.

**Material:**  
Enclosure, roof and side panel: 2.0 mm aluminium AlMg3  
Base/plinth: 3.0 mm aluminium AlMg3

**Colour:**  
RAL 7035

## Protection category:

IP 55 to EN 60 529/09.2000, complies with NEMA 3R.

## Supply includes:

Twin-walled, fully assembled enclosure, consisting of basic module, roof, side panels and base/plinth.

## Note:

Modular enclosures with climate control units, as bayed suites, with side doors or rear doors available on request.

## Property rights:

German patents  
no. 196 09 699 and 196 09 704  
European patents  
no. 0 886 899 and 0 886 900 with validity for FR, IT, GB, SE  
US patents no. 6,109,053 and 5,971,511  
South Korean patents  
no. 0 334 548 and 0 325 930  
Japan. patent no. 3 401 015

**Detailed drawing,**  
see page 1298 – 1299.

Width (B1) mm	Packs of	600	800	800	1200	Page
Height (H1) mm		1200	1200	1600	1200	
Depth (T1) mm		600	500	600	600	
Clearance width (B2) mm		512	712	712	512	
Clearance height (H2) mm		1112	1112	1512	1112	
Clearance depth (T2) mm		554	454	554	554	
Rain canopy width (B3) mm		700	900	900	1300	
Rain canopy height (H3) mm		75	75	75	75	
Rain canopy depth (T3) mm		650	550	650	650	
Base/plinth height (H4) mm		100	100	100	100	
Overall height (H5) mm		1375	1375	1775	1375	
<b>Model No. CS</b>	<b>1</b>	<b>9751.125</b>	<b>9751.145</b>	<b>9751.165</b>	<b>9752.125</b>	
<b>Accessories</b>						
Concrete base/plinth	1	9765.083	9765.084	9765.085	9765.087	900
Mounting plate	1	9765.092	9765.095	9765.096	9765.191	987
Mounting angles, 482.6 mm (19")	2	7688.000	7688.000	7690.000	7688.000	1093
Installation kit for 482.6 mm (19") mounting angles	2	7696.000	7698.000	7698.000	7696.000	1093
Mounting angles, metric (T-slot)	2	–	7000.240	7000.330	–	1093
Installation kit for metric mounting angles	2	–	7000.100	7000.100	–	1093
Gland plate	Size	4	4	4	4	From 1048
	No. of	2	4	4	4	
Support rails	4	4396.000	4395.000	4396.000	4396.000	1001
Heater 800 W	1	9769.080	9769.080	9769.080	9769.080	709
Thermostat	1	3110.000	3110.000	3110.000	3110.000	715
Enclosure light 48 V DC	1	9765.150	9765.150	9765.150	9765.150	1029

# CS modular enclosures

## Installation variants, width 600 mm

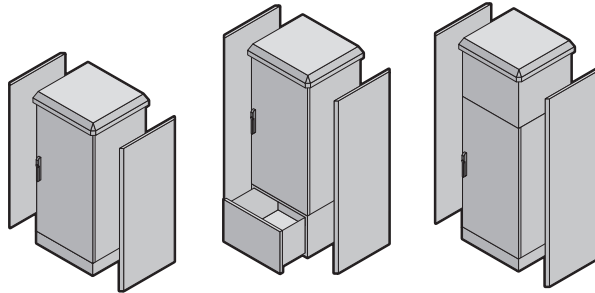

**Material:**  
Enclosure, roof and side panel:  
2.0 mm aluminium AIMg3  
Base/plinth, battery plinth:  
3.0 mm aluminium AIMg3

**Colour:**  
RAL 7035  
**Protection category:**  
IP 55 to EN 60 529/09.2000,  
complies with NEMA 3R.

**Other climate control devices,**  
from page 883.  
**Note:**  
Please note the minimum enclosure dimensions when making your selection.

The enclosures are manufactured to order from individual modules.  
Delivery times available on request.

<b>Width (W) mm</b>	600	600	600	600	Page
<b>Height (H) mm</b>	800	1000	1200	1600	
<b>Depth (D) mm</b>	600	500	600	600	
<b>Model No. CS</b>	<b>9751.015</b>	<b>9751.075</b>	<b>9751.025</b>	<b>9751.035</b>	
<b>Base/plinth</b>					
Standard base/plinth 100 mm	<b>9755.015</b>	<b>9755.065</b>	<b>9755.015</b>	<b>9755.015</b>	
Battery plinth 350 mm	<b>9754.025</b>	<b>9754.015</b>	<b>9754.025</b>	<b>9754.025</b>	
<b>Roof-mounted climate control</b>					
Cooling unit	9762.012	9762.012	9762.012	9762.012	883
Heat exchangers	9764.012	9764.012	9764.012	9764.012	884
Mounting frame for heat exchanger or cooling unit	<b>9765.051</b>	<b>9765.051</b>	<b>9765.051</b>	<b>9765.051</b>	
Climate hood	<b>9756.015</b>	<b>9756.065</b>	<b>9756.015</b>	<b>9756.015</b>	
<b>Wall-mounted climate control</b>					
Cooling unit	-	-	9761.012	9761.012	883
Heat exchangers	-	-	9763.012	9763.012	884
<b>Roof</b>					
Standard roof	<b>9757.015</b>	<b>9757.065</b>	<b>9757.015</b>	<b>9757.015</b>	
Roof for wall-mounted climate control	-	-	<b>9758.015</b>	<b>9758.015</b>	
<b>Side panel</b>					
Side panel for 100 mm base/plinth	<b>9753.015</b>	<b>9753.175</b>	<b>9753.035</b>	<b>9753.045</b>	
Side panel for 350 mm base/plinth	<b>9753.055</b>	<b>9753.195</b>	<b>9753.075</b>	<b>9753.085</b>	
Side panel for 100 mm base/plinth and roof-mounted climate control	<b>9753.095</b>	<b>9753.185</b>	<b>9753.115</b>	<b>9753.125</b>	
Side panel for 350 mm base/plinth and roof-mounted climate control	<b>9753.135</b>	<b>9753.205</b>	<b>9753.155</b>	<b>9753.165</b>	

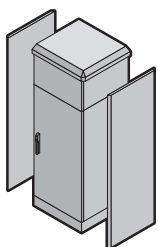

**Order example:**  
Enclosure 800 x 800 x 600 mm of aluminium AIMg3 with standard base/plinth and roof-mounted cooling unit.

**You will need:**

<b>Enclosure:</b>	Basic enclosure 600 x 800 x 600 mm	<b>CS 9751.015</b>
<b>Base/plinth:</b>	Standard base/plinth 100 mm	<b>CS 9755.015</b>
<b>Roof-mounted climate control:</b>	Roof-mounted cooling unit	<b>CS 9762.012</b>
	Mounting frame	<b>CS 9765.051</b>
	Climate hood	<b>CS 9756.015</b>
<b>Roof:</b>	Standard roof	<b>CS 9757.015</b>
<b>Side panel:</b>	Side panel for 100 mm base/plinth and roof-mounted climate control	<b>CS 9753.095</b>

# CS modular enclosures

## Installation variants, width 800/1200 mm

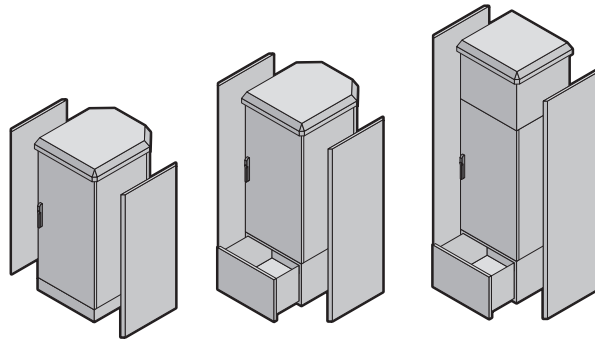

**Material:**  
Enclosure, roof and side panel:  
2.0 mm aluminium AlMg3  
Base/plinth, battery plinth:  
3.0 mm aluminium AlMg3

**Colour:**  
RAL 7035  
**Protection category:**  
IP 55 to EN 60 529/09.2000,  
complies with NEMA 3R.

**Other climate control devices,**  
from page 883.  
**Note:**  
Please note the minimum enclosure dimensions when making your selection.

The enclosures are manufactured to order from individual modules.  
Delivery times available on request.

<b>Width (W) mm</b>	800	800	800	800	1200	1200	Page
<b>Height (H) mm</b>	1000	1200	1200	1600	1200	1200	
<b>Depth (D) mm</b>	500	500	600	600	500	600	
<b>Model No. CS</b>	<b>9751.085</b>	<b>9751.045</b>	<b>9751.055</b>	<b>9751.065</b>	<b>9752.015</b>	<b>9752.025</b>	
<b>Base/plinth</b>							
Standard base/plinth 100 mm	<b>9755.025</b>	<b>9755.025</b>	<b>9755.035</b>	<b>9755.035</b>	<b>9755.045</b>	<b>9755.055</b>	
Battery plinth 350 mm	<b>9754.035</b>	<b>9754.035</b>	<b>9754.045</b>	<b>9754.045</b>	2 x <b>9754.015</b>	2 x <b>9754.025</b>	
<b>Roof-mounted climate control</b>							
Cooling unit	9762.012	9762.012	9762.012	9762.012	9762.012	9762.012	883
Heat exchangers	9764.012	9764.012	9764.012	9764.012	9764.012	9764.012	884
Mounting frame for heat exchanger or cooling unit	<b>9765.051</b>	<b>9765.051</b>	<b>9765.051</b>	<b>9765.051</b>	<b>9765.051</b>	<b>9765.051</b>	
Climate hood	<b>9756.025</b>	<b>9756.025</b>	<b>9756.035</b>	<b>9756.035</b>	<b>9756.045</b>	<b>9756.055</b>	
<b>Wall-mounted climate control</b>							
Cooling unit	–	9761.032	9761.032	9761.032	9761.012	9761.012	883
Heat exchangers	–	9763.012	9763.012	9763.012	9763.012	9763.012	884
<b>Roof</b>							
Standard roof	<b>9757.025</b>	<b>9757.025</b>	<b>9757.035</b>	<b>9757.035</b>	<b>9757.045</b>	<b>9757.055</b>	
Roof for wall-mounted climate control	–	<b>9758.025</b>	<b>9758.035</b>	<b>9758.035</b>	<b>9758.045</b>	<b>9758.055</b>	
<b>Side panel</b>							
Side panel for 100 mm base/plinth	<b>9753.175</b>	<b>9753.025</b>	<b>9753.035</b>	<b>9753.045</b>	<b>9753.025</b>	<b>9753.035</b>	
Side panel for 350 mm base/plinth	<b>9753.195</b>	<b>9753.065</b>	<b>9753.075</b>	<b>9753.085</b>	<b>9753.065</b>	<b>9753.075</b>	
Side panel for 100 mm base/plinth and roof-mounted climate control	<b>9753.185</b>	<b>9753.105</b>	<b>9753.115</b>	<b>9753.125</b>	<b>9753.105</b>	<b>9753.115</b>	
Side panel for 350 mm base/plinth and roof-mounted climate control	<b>9753.205</b>	<b>9753.145</b>	<b>9753.155</b>	<b>9753.165</b>	<b>9753.145</b>	<b>9753.155</b>	

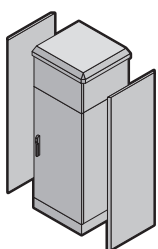

**Order example:**  
Enclosure 800 x 1200 x 500 mm of aluminium AlMg3 with standard base/plinth and roof-mounted cooling unit.

**You will need:**

<b>Enclosure:</b>	Basic enclosure 800 x 1200 x 500 mm	<b>CS 9751.045</b>
<b>Base/plinth:</b>	Standard base/plinth 100 mm	<b>CS 9755.025</b>
<b>Roof-mounted climate control:</b>	Roof-mounted cooling unit	<b>CS 9762.012</b>
	Mounting frame	<b>CS 9765.051</b>
	Climate hood	<b>CS 9756.025</b>
<b>Roof:</b>	Standard roof	<b>CS 9757.025</b>
<b>Side panel:</b>	Side panel for 100 mm base/plinth and roof-mounted climate control	<b>CS 9753.105</b>

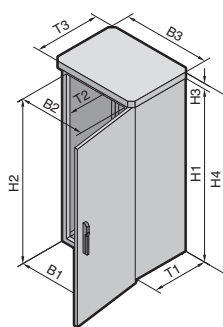

### Material:

Enclosure frame:  
1.5 mm stainless steel 1.4301  
(AISI 304)  
Rain canopy:  
2.0 mm aluminium, AlMg3  
Doors, side panels, base/plinth  
trim:  
Sheet steel, hot-galvanised

### Surface finish:

Zinc-phosphated, powder-  
coated in RAL 7035

### Protection category:

IP 55 to EN 60 529/09.2000

### Supply includes:

Double-walled outdoor enclosure fully pre-configured.  
Rigid enclosure body, consisting of vertical sections based on TS 8, roof and integral base/plinth assembly.  
Outer roof, door front and rear, side panels left and right secured to the enclosure frame and doubled on the inside, to allow baying possibilities.  
Doors doubled by 25 mm on the outside and ventilated, r/h hinge, with swing lever handle and semi-cylinder with security lock.  
Door stay lock for a door opening angle of 90°, 115° or 135°.  
Roof with front and rear projection, vented.

Outer side panel screw-fastened from the inside, combined to form one unit with the inner side panel. Side panels removable, offering full side accessibility. Integral base/plinth including two screw-fastened gland plates for cable entry. Front and rear base/plinth trim screw-fastened to the enclosure frame must be dismantled to gain access to the mounting holes for the concrete base/plinth or foundation. Protection against removal of the roof, side panels and base/plinth trim.

### Note:

The outer mounting level of the TS 8 vertical sections may only be used in the enclosure depth to a limited extent, as the side panel protrudes into the level.



### Rittal service:

Toptec CR, 800 mm wide, with integral cooling unit or air/air heat exchanger, see page 886 for output data.

**Detailed drawing,**  
see page 1300.

	Packs of	610	810	610	810	Page
<b>Width (B1) mm</b>						
<b>Height (H1) mm</b>		1200	1200	1600	1600	
<b>Depth (T1) mm</b>		653	653	653	653	
Clearance width (B2) mm		512	712	512	712	
Clearance height (H2) mm		1112	1112	1512	1512	
Clearance depth (T2) mm		512	512	512	512	
Rain canopy width (B3) mm		610	810	610	810	
Rain canopy height (H3) mm		40	40	40	40	
Rain canopy depth (T3) mm		700	700	700	700	
Overall height (H4) mm		1299	1299	1699	1699	
<b>Model No. CS</b>	1	<b>9775.100</b>	<b>9775.200</b>	<b>9775.300</b>	<b>9775.400</b>	
<b>Accessories</b>						
Concrete base/plinth	1	9765.166	9765.186	9765.166	9765.186	900
Mounting angles, 482.6 mm (19") full installation	2	7827.120	7827.120	7827.160	7827.160	1091
Installation kit for 482.6 mm (19") mounting angles	4	8612.060	7794.580	8612.060	7794.580	1095, 1096
Mounting kit CS for roof and base frame	4	9765.155	9765.155	9765.155	9765.155	987
Mounting plate	1	9765.092	9765.095	9765.093	9765.096	987
Gland plate	Size	4	4	4	4	From 1048
	No. of	2	2	2	2	
Eyebolts	4	4568.000	4568.000	4568.000	4568.000	974
Semi-cylinder	1	9785.040	9785.040	9785.040	9785.040	957

# CS Basic enclosures

## single-door, width 600 mm

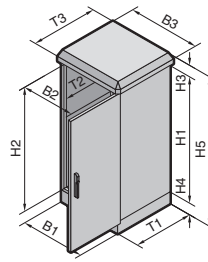

**Material:**  
Enclosure, roof and doors:  
2.0 mm aluminium AlMg3  
Base/plinth:  
3.0 mm aluminium AlMg3

**Colour:**  
RAL 7035

**Protection category:**  
IP 55 to EN 60 529/09.2000 in  
conjunction with the gland  
plates available as accessories.

**Supply includes:**  
Single-walled enclosure of  
all-round solid construction,  
with open base,  
3-point locking via Ergoform  
padlock and lock cylinder,  
base/plinth, rain canopy.

**Detailed drawing,**  
see page 1301.

**Note:**  
When installing a mounting plate  
in the rearmost position, addi-  
tional vertical mounting rails are  
required in the enclosure height,  
see page 998.

Width (B1) mm	Packs of	600	600	600	600	Page
Height (H1) mm		800	1200	1400	1200	
Depth (T1) mm		400	400	400	500	
Clearance width (B2) mm		512	512	512	512	
Clearance height (H2) mm		712	1112	1312	1112	
Clearance depth (T2) mm		349	349	349	449	
Rain canopy width (B3) mm		650	650	650	650	
Rain canopy height (H3) mm		75	75	75	75	
Rain canopy depth (T3) mm		450	450	450	550	
Base/plinth height (H4) mm		100	100	100	100	
Overall height (H5) mm		975	1375	1575	1375	
<b>Model No. CS</b>	1	<b>9783.040</b>	<b>9783.050</b>	<b>9783.060</b>	<b>9783.030</b>	
<b>Accessories</b>						
Concrete base/plinth	1	9765.182	9765.182	9765.182	9765.082	900
One-piece gland plate	1 set	9785.017	9785.017	9785.017	9785.020	913
Gland plate, divided	1 set	9785.011	9785.011	9785.011	9785.014	913
Cable entry plate	2	4320.700	4320.700	4320.700	4320.700	1045
Mounting plate	1	9765.090	9765.092	9765.098	9765.092	987
Mounting angles 482.6 mm (19"), full installation	2	7685.000	7688.000	7689.000	7688.000	1093
Installation kit for mounting angles	2	7696.000	7696.000	7696.000	7696.000	1093
Heater 800 W	1	9769.080	9769.080	9769.080	9769.080	709
Thermostat	1	3110.000	3110.000	3110.000	3110.000	715

# CS Basic enclosures

single-door, width 800 mm

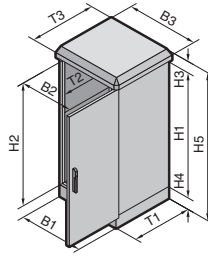

**Material:**

Enclosure, roof and doors:  
2.0 mm aluminium AlMg3  
Base/plinth:  
3.0 mm aluminium AlMg3

**Colour:**

RAL 7035

**Protection category:**

IP 55 to EN 60 529/09.2000 in conjunction with the gland plates available as accessories.

**Supply includes:**

Single-walled enclosure of all-round solid construction, with open base, 3-point locking via Ergoform padlock and lock cylinder, base/plinth, rain canopy.

**Detailed drawing,**

see page 1301.

**Note:**

When installing a mounting plate in the rearmost position, additional vertical mounting rails are required in the enclosure height, see page 998.

Width (B1) mm	Packs of	800	800	800	800	Page
<b>Height (H1) mm</b>		800	1200	1400	1200	
<b>Depth (T1) mm</b>		400	400	400	500	
Clearance width (B2) mm		712	712	712	712	
Clearance height (H2) mm		712	1112	1312	1112	
Clearance depth (T2) mm		349	349	349	449	
Rain canopy width (B3) mm		850	850	850	850	
Rain canopy height (H3) mm		75	75	75	75	
Rain canopy depth (T3) mm		450	450	450	550	
Base/plinth height (H4) mm		100	100	100	100	
Overall height (H5) mm		975	1375	1575	1375	
<b>Model No. CS</b>	1	<b>9783.010</b>	<b>9783.020</b>	<b>9783.120</b>	<b>9783.110</b>	
<b>Accessories</b>						
Concrete base/plinth	1	9765.088	9765.088	9765.088	9765.084	900
One-piece gland plate	1 set	9785.018	9785.018	9785.018	9785.019	913
Gland plate, divided	1 set	9785.012	9785.012	9785.012	9785.013	913
Cable entry plate	2	4321.700	4321.700	4321.700	4321.700	1045
Mounting plate	1	9765.097	9765.095	9765.099	9765.095	987
Mounting angles 482.6 mm (19"), full installation	2	7685.000	7688.000	7689.000	7688.000	1093
Installation kit for mounting angles	2	7698.000	7698.000	7698.000	7698.000	1093
Heater 800 W	1	9769.080	9769.080	9769.080	9769.080	709
Thermostat	1	3110.000	3110.000	3110.000	3110.000	715

# CS Basic enclosures

## two-door, width 1200 mm

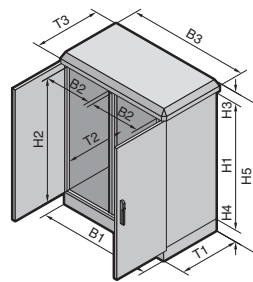

**Material:**  
Enclosure, roof and doors:  
2.0 mm aluminium AlMg3  
Base/plinth:  
3.0 mm aluminium AlMg3

**Colour:**  
RAL 7035

**Protection category:**  
IP 55 to EN 60 529/09.2000 in  
conjunction with the gland  
plates available as accessories.

**Supply includes:**  
Single-walled enclosure of  
all-round solid construction,  
with open base,  
3-point locking via Ergoform  
padlock and lock cylinder  
Version without centre bar:  
overlapping doors,  
lockable door with r/h hinge.  
Version with centre bar:  
2 lockable doors,  
base/plinth, rain canopy,  
centre bar can be dismantled.

**Detailed drawing,**  
see page 1301.

**Note:**  
When installing a mounting plate  
in the rearmost position, addi-  
tional vertical mounting rails are  
required in the enclosure height,  
see page 998.

Width (B1) mm	Packs of	1200	1200	1200	1200	Page
<b>Height (H1) mm</b>		800	1200	1200	1400	
<b>Depth (T1) mm</b>		400	400	500	400	
Clearance width (B2) mm		512	512	512	512	
Clearance height (H2) mm		712	1112	1112	1312	
Clearance depth (T2) mm		349	349	449	349	
Rain canopy width (B3) mm		1250	1250	1250	1250	
Rain canopy height (H3) mm		75	75	75	75	
Rain canopy depth (T3) mm		450	450	550	450	
Base/plinth height (H4) mm		100	100	100	100	
Overall height (H5) mm		975	1375	1375	1575	
<b>Model No. CS without centre bar</b>	1	<b>9784.110</b>	<b>9784.120</b>	<b>9784.140</b>	<b>9784.130</b>	
<b>Model No. CS with centre bar</b>	1	<b>9784.010<sup>1)</sup></b>	<b>9784.020</b>	<b>9784.040</b>	<b>9784.030</b>	
<b>Accessories</b>						
Concrete base/plinth	1	9765.089	9765.089	9765.086	9765.089	900
One-piece gland plate	1 set	2 x 9785.017	2 x 9785.017	2 x 9785.020	2 x 9785.017	913
Gland plate, divided	1 set	2 x 9785.011	2 x 9785.011	2 x 9785.014	2 x 9785.011	913
Cable entry plate	2	4320.700	4320.700	4320.700	4320.700	1045
Mounting plate for one half of the enclosure	1	9765.090	9765.092	9765.092	9765.098	987
Mounting plate (full width)	1	9765.190	9765.191	9765.191	9765.192	987
482.6 mm (19") mounting angles for one half of the enclosure	2	7685.000	7688.000	7688.000	7689.000	1093
Installation kit for mounting angles	2	7696.000	7696.000	7696.000	7696.000	1093
Heater 800 W	1	9769.080	9769.080	9769.080	9769.080	709
Thermostat	1	3110.000	3110.000	3110.000	3110.000	715

<sup>1)</sup> Delivery times available on request.

# CS wall-mounted enclosures

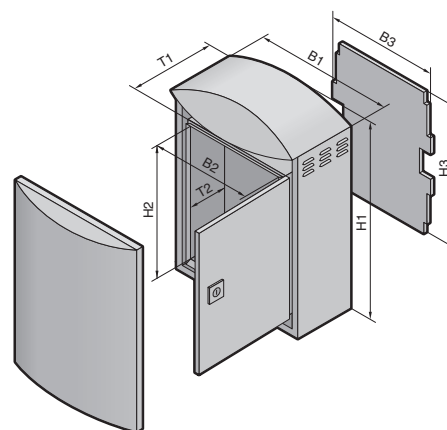

## Material:

Aluminium AIMg3  
Enclosure:  
Exterior: 2.0 mm  
Interior: 1.5 mm/2.0 mm  
Doors: 2.0 mm  
Mounting plate/rotating frame:  
2.0 mm clear-chromated

## Colour:

RAL 7035

## Protection category:

IP 55 to EN 60 529/09.2000

## Supply includes:

Inner enclosure with door,  
aluminium mounting plate or  
rotating frame,  
security lock (CS 9791.045 and  
CS 9791.145 with 2 security  
locks),  
foamed in door seals,  
gland plate at bottom,  
mounting bracket for thermostat,  
outer enclosure with integral  
vent louvres,  
designer cover with security  
lock, C rails on the rear panel.

## Property rights for wall-mounted enclosure with mounting plate:

German registered design  
no. 97 08 625  
UK registered design  
no. 2 072 965  
IR reg. design no. DM/044 110  
with validity for ES, FR, IT,  
Indonesia  
US patent no. 6,024,236  
European patent no. 0 902 514  
with validity for FI, GB, SE  
Japan. patent no. 3 189 210

- 1 Wall-mounted enclosure with mounting plate
- 2 482.6 mm (19") rotating frame



## Rittal service:

**Complete interior installation**  
of the wall-mounted enclosure  
up to integration Level 4 to the  
customer's specifications is  
available.

**Detailed drawing,**  
see page 1302.

Width (B1) mm	Packs of	370/300	420/350	530/460	630/580	630/580	Page
Height (H1) mm		522.5/400	560.5/440	700/565	780/580	780/580	
Depth (T1) mm		210/170	210/170	265/220	380/333	380/333	
Clearance width (B2) mm		280	330	440	560	560	
Clearance height (H2) mm		380	420	545	560	560	
Clearance depth (T2) mm		145	145	195	308	240 <sup>2)</sup>	
Mounting plate width (B3) mm		270	320	430	550	-	
Mounting plate height (H3) mm		380	410	535	550	-	
<b>Model No. CS</b>	<b>1</b>	<b>9791.015</b>	<b>9791.025</b>	<b>9791.035</b>	<b>9791.045</b>	<b>9791.145<sup>1)</sup></b>	
<b>Accessories</b>							
Wall mounting bracket	4	9765.120	9765.120	9765.120	9765.120	9765.120	976
Pole clamp	1 set	9765.125	9765.125	9765.125	9765.125	9765.125	976
Heater, 30 W	1	3115.000	3115.000	3115.000	3115.000	3115.000	709
Thermostat	1	3110.000	3110.000	3110.000	3110.000	3110.000	715

<sup>1)</sup> With 5 U rotating frame instead of mounting plate.

<sup>2)</sup> Max. installation depth in the 482.6 mm (19") level.

# CS Outdoor climate control

## Features



Rittal Communication Systems offer everything you need to protect your electronic equipment, from weather-tested enclosure solutions, to a variety of climate control components, through to complete security management systems. Cooling units, heat exchangers, fans and heaters especially designed for outdoor use ensure constant interior temperatures.

The protection category of IP 55 for the system as a whole is retained when using Outdoor heat exchangers and cooling units.

CS Outdoor climate control



### Flexible climate control



**Climate control modules** in various different output levels may be positioned on the door, rear panel, side panel or roof of the modular enclosure.



Suitable for use within a temperature range from  $-33^{\circ}\text{C}$  to  $+55^{\circ}\text{C}$  (with cooling unit) or  $+65^{\circ}\text{C}$  (with heat exchanger).



Many units feature an integral heater. **Heaters** may be snap-mounted onto **top hat rails** inside the enclosure using the quick-assembly system.



The **full 25 mm double wall** assists heat management and minimises the influence of sunlight.



**Active climate control concept** with fixed cut-out sizes and a mounting frame for depth-variable positioning of the climate control unit.



Depending on the local conditions at the installation site, either a heat exchanger or a cooling unit may be used.

B  
6.2

# CS Outdoor climate control

## Cooling units for CS modular enclosures



**Type 1 for roof mounting**  
With microcontroller and 400 watt heater as standard.

**Mounting frame:**  
Required for CS 9762.012.

**Type 2 for door mounting**  
With microcontroller and 400 watt heater as standard.



**Type 3 for wall mounting**  
With microcontroller and 400 watt heater as standard. Alternative mounting on the rear or side panels is also possible. The picture shows the cooling unit with designer cover (not included in the supply).

**Type 4 for universal installation**  
With microcontroller and 800 watt heater as standard.

**Installation options:**

- in the door or rear panel
- in the side panel

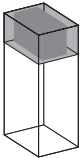
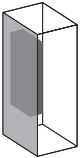
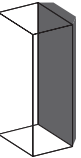
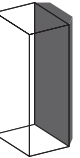
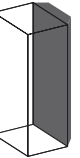
**Approvals,**  
see page 104.

								
<b>Model No. CS</b>		<b>9762.012</b>	<b>9768.100</b>	<b>9761.012</b>	<b>9761.032</b>	<b>9761.042</b>	<b>9768.150</b>	Page
Mounting		Type 1 Roof-mounted	Type 2 Door-mounted	Type 3 Wall-mounted			Type 4 Universal	
Rated operating voltage	AC	230 V, 50/60 Hz						
Unit dimensions mm	W	535	430	515	695	776	400	
	H	390	1070	1170	1132	1100	1050	
	D	400	210	151.5	151.5	250	310	
Minimum enclosure dimensions mm	W x H/D x H	–	600 x 1200	600 x 1200	800 x 1200	800 x 1200	600 x 1200	
	W x D	600 x 500	–	–	–	–	–	
<b>Useful cooling output EN 814</b>	<b>L35 L35 L35 L50</b>	<b>900 W 750 W</b>	<b>900 W 650 W</b>	<b>900 W 750 W</b>	<b>1400 W 1050 W</b>	<b>2500 W 2000 W</b>	<b>1500 W 1250 W</b>	
Heater		400 W	400 W	400 W	400 W	400 W	800 W	
Rated current max.		4.0 A	4.0 A	3.5 A	5.5 A	10.0 A	5.8 A	
Start-up current max.		10.7 A	11.6 A	10.8 A	15.5 A	32.0 A	19.0 A	
Power consumption	L35 L35	460 W	470 W	450 W	900 W	1450 W	940 W	
	L35 L50	520 W	530 W	520 W	1000 W	1650 W	1045 W	
Coolant		R134a						
p. max.		26 bar	28 bar	24 bar	24 bar	28 bar	28 bar	
Temperature range		–33°C to +55°C						
Air throughput of fans – unimpeded air flow	Internal circuit fan	570 m <sup>3</sup> /h	580 m <sup>3</sup> /h	880 m <sup>3</sup> /h	850 m <sup>3</sup> /h	1450 m <sup>3</sup> /h	850 m <sup>3</sup> /h	
	External circuit fan	570 m <sup>3</sup> /h	430 m <sup>3</sup> /h	880 m <sup>3</sup> /h	880 m <sup>3</sup> /h	1450 m <sup>3</sup> /h	680 m <sup>3</sup> /h	
Temperature control		Microcontroller <sup>1)</sup>						
Type of connection		Plug panel						
Weight		29 kg	31 kg	45 kg	48 kg	52 kg	40 kg	
Protection category to EN 60 529/09.2000		IP 55 (internal circuit to external circuit)						
Material (enclosure)		Aluminium			Sheet steel		Aluminium	
Surface finish		Spray-finished in RAL 7035						
CE Declaration of Conformity		■	■	■	■	■	■	
UL/CUL		–	–	■	■	–	–	
<b>Accessories</b>								
Cable connection kit		9765.105	9765.105	9765.105	9765.105	9765.105	9765.105	717
Mounting frame		<b>9765.051</b>	–	–	–	–	–	–

<sup>1)</sup> With temperature-controlled activation of the components (internal/external circuit, heater). Setpoints are preset. Modifications can only be made by arrangement.

### Delivery times available on request.

Cooling units for modular enclosures are manufactured to order. The units are assembled and supplied connected to the modular enclosure. Adaptations to other enclosure platforms are available on request.

# CS Outdoor climate control

## Heat exchangers for CS modular enclosures



**Type 1 for roof mounting**  
Without microcontroller,  
without heater.



**Type 2 for roof mounting**  
With microcontroller and heater  
as standard.



**Mounting frame:**  
Required for CS 9764.012.



**Type 3 for wall mounting**  
With microcontroller and heater  
as standard. For external mount-  
ing on side or rear panels.  
The picture shows the heat  
exchanger with designer cover  
(not included in the supply).

**Property rights for Type 1  
and 2:**

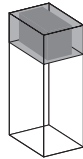
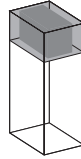
German patent  
no. 196 09 796  
US patent no. 6,092,384  
European patent no. 0 913 015  
with validity for FR, GB, IT, SE  
Japan. patent no. 32 79 576  
South Korean patent  
no. 0 337 973

					
Model No. CS		<b>9764.040</b>	<b>9764.012</b>	<b>9763.012</b>	Page
Mounting		Type 1 Roof-mounted	Type 2 Roof-mounted	Type 3 Wall-mounted	
Rated operating voltage	DC (fan/ microcontroller)	48 V			
	AC (heater)	–	230 V, 50/60 Hz		
Unit dimensions mm	W	470	535	515	
	H	158	390	1170	
	D	380	400	151.5	
Minimum enclosure dimensions mm	W x H/D x H	–	–	600 x 1200	
	W x D	600 x 500	600 x 500	–	
<b>Specific thermal output</b>		<b>30 W/K</b>	<b>60 W/K</b>	<b>60 W/K</b>	
Heater		–	400 W	400 W	
Rated current max.	DC (fan/ microcontroller)	1.3 A	3.1 A	3.2 A	
	AC (heater)	–	1.9 A	1.9 A	
Temperature range		–33°C to +65°C			
Air throughput of fans – unimpeded air flow	Internal/external circuit fan	345 m³/h	830 m³/h	830 m³/h	
Temperature control		without <sup>1)</sup>	Microcontroller <sup>2)</sup>		
Type of connection		Plug panel			
Weight		7 kg	17 kg	31 kg	
Protection category to EN 60 529/09.2000		IP 55 (internal circuit to external circuit)			
Material (enclosure)		Aluminium		Sheet steel	
Surface finish		Spray-finished in RAL 7035			
CE Declaration of Conformity		■	■	■	
UL/CUL		–	■	■	
<b>Accessories</b>					
Cable connection kit		9765.110	9765.110	9765.110	717
Thermostat		3110.000	–	–	715
Mounting frame		–	<b>9765.051</b>	–	–

<sup>1)</sup> Customers may fit their own temperature control (SK 3110.000).

<sup>2)</sup> With temperature-controlled activation of the components (internal/external circuit, heater).  
Setpoints are preset. Modifications can only be made by arrangement.

**Delivery times available on request.**

Heat exchangers for modular enclosures are manufactured to order. The units are assembled and supplied connected to the modular enclosure. Adaptations to other enclosure platforms are available on request.

# CS Outdoor climate control

## Heat exchangers for CS modular enclosures



**Type 4 for door mounting**  
With microcontroller and  
400 watt heater as standard.

**Type 5 for door mounting**  
With microcontroller and heater  
as standard.

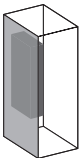
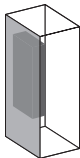
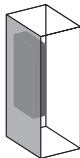
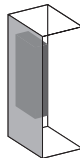
						
Model No. CS		9768.032	9768.012	9768.042	9768.062	Page
Mounting		Type 4 Door-mounted		Type 5 Door-mounted		
Rated operating voltage	DC (fan/ microcontroller)	48 V				
	AC (heater)	230 V, 50/60 Hz		–		
Unit dimensions mm	W	480	510	445	575	
	H	1005	1005	1050	1050	
	D	110	150	150	195	
Minimum enclosure dimensions mm	W	600	650	650	800	
	H	1200	1200	1300	1300	
<b>Specific thermal output</b>		<b>40 W/K</b>	<b>60 W/K</b>	<b>85 W/K</b>	<b>120 W/K</b>	
Heater		400 W		–		
Rated current max.	DC (fan/ microcontroller)	2.0 A	3.2 A	6.4 A	7.9 A	
	AC (heater)	1.9 A		–		
Temperature range		–33°C to +65°C				
Air throughput of fans – unimpeded air flow	Internal/external circuit fan	515 m³/h	530 m³/h	1020 m³/h		
Temperature control		Microcontroller <sup>1)</sup>				
Type of connection		Plug panel			Sub-D connector 13W3 <sup>2)</sup>	
Weight		13 kg	15 kg	28 kg	32 kg	
Protection category to EN 60 529/09.2000		IP 55 (internal circuit to external circuit)				
Material (enclosure)		Aluminium				
Surface finish		Spray-finished in RAL 7035				
CE Declaration of Conformity		■	■	■	■	
UL/CUL		■	■	■	■	
<b>Accessories</b>						
Cable connection kit		9765.110	9765.110	9765.115	–	717

<sup>1)</sup> With temperature-controlled activation of the components (internal/external circuit, heater).

Setpoints are preset. Modifications can only be made by arrangement.

<sup>2)</sup> Special connection cable included in the supply.

### Delivery times available on request.

Heat exchangers for modular enclosures are manufactured to order. The units are assembled and supplied connected to the modular enclosure. Adaptations to other enclosure platforms are available on request.

# CS Outdoor climate control

## Climate control units for Toptec CR

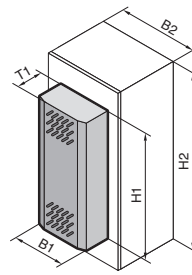

B = Width  
T = Depth

**1 Heat exchanger/cooling unit**  
With three mounting positions for internal mounting, partial internal mounting or external mounting plus a choice between cooling via front or rear door.

**2 Heat exchanger/cooling unit,**  
built into the Toptec CR.

		Heat exchangers		Cooling units		Page
Model No. CS		9776.100	9776.150	9776.500	9776.550	
Mounting		Universal		Universal		
Rated operating voltage	DC	48 V		–		
	AC	–		230 V, 50/60 Hz		
Unit dimensions mm	B1	500	500	500	500	
	H1	1000	1000	1000	1000	
	T1	150	200	150	260	
Minimum enclosure dimensions mm	W x H	800 x 1200		800 x 1200		
<b>Specific thermal output</b>		<b>85 W/K</b>	<b>105 W/K</b>	–	–	
<b>Useful cooling output EN 814</b>	L35 L35 L35 L50	–	–	<b>1000 W/1180 W 650 W/700 W</b>	<b>1600 W/1750 W 1200 W/1250 W</b>	
Heater		–	–	400 W		
Rated current max.	DC	4.2 A	4.5 A	–	–	
	AC	–		5.0 A/5.0 A	6.0 A/6.8 A	
Start-up current max.		–		24.0 A/22.0 A	34.0 A/32.0 A	
Power consumption	L35 L35	–		640 W/760 W	960 W/1170 W	
	L35 L50	–		780 W/920 W	1125 W/1310 W	
Coolant		–		R134a		
p. max.		–		28 bar	28 bar	
Temperature range		–33°C to +65°C		–33°C to +55°C		
Air throughput of fans – unimpeded air flow	Internal/external circuit fan	530 m³/h	1130 m³/h	600/625 m³/h 600/625 m³/h	880/950 m³/h 1000/1090 m³/h	
	Temperature control	Microcontroller <sup>1)</sup>		Microcontroller <sup>2)</sup>		
Type of connection		Plug panel		Female multi-point connector 9-pole		
Weight		22 kg	30 kg	35 kg	45 kg	
Protection category to EN 60 529/09.2000		IP 55 (internal circuit to external circuit)				
Material (enclosure)		Aluminium				
Surface finish		Spray-finished in RAL 7035				
CE Declaration of Conformity		■	■	■	■	
<b>Accessories</b>						
Cable connection kit		9765.115	–	–	–	717

<sup>1)</sup> With temperature-controlled activation of the components (internal/external circuit, heater).  
Setpoints are preset. Modifications can only be made by arrangement.

<sup>2)</sup> Settings may be amended directly on the unit display.

## Geothermal heat exchanger, Terravent

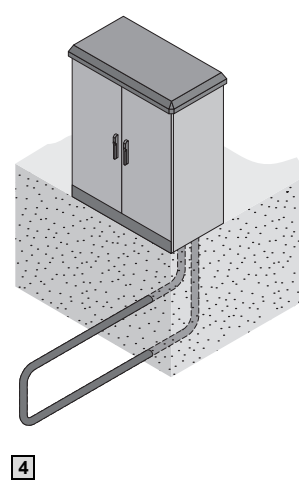
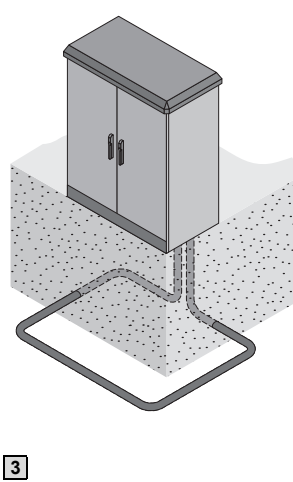
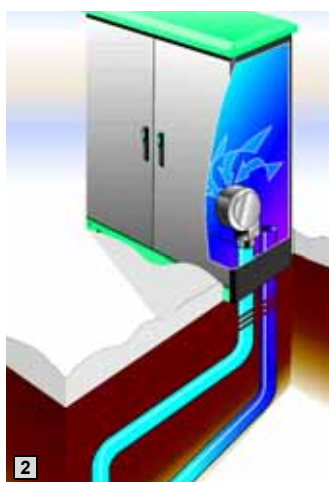
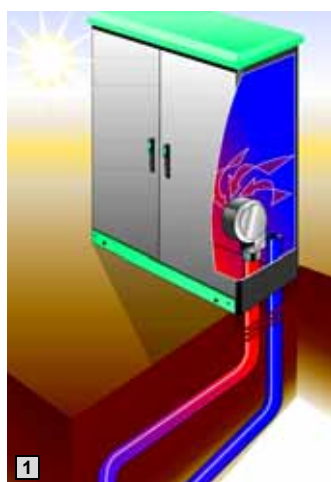

### Rittal Terravent

This ingeniously simple and effective climate control principle, which uses geothermal effects to cool and heat, underscores Rittal's expertise in all aspects of enclosure systems for outdoor siting. The geothermal heat transmitter is suitable for use whenever earthworks are required to install an outdoor enclosure.

Throughout the world, at a certain depth beneath the earth's crust, the temperature is always roughly the same, whatever the season; and this fact is used to cool and heat outdoor enclosures. The hot air from the enclosure is forced into a pipe with a radial or axial fan.

A pipeline system laid in the earth cools the air, which in turn is used to cool the enclosure. In cool external temperatures, the temperature of the air inside the pipeline system rises, and this achieves a heating effect.

The inlet and outlet points of the pipes can be freely positioned to effectively avoid hotspots. Depending on the application, the air discharge and air inlet can be positioned in the base/plinth, in the roof, or at freely selectable positions inside the enclosure.

### Benefits of the geothermal heat exchanger

- With the sealed ventilation system, ambient air is unable to penetrate the enclosure, which in turn prevents the ingress of humidity and aggressive pollutants from the air.
- Minimal energy requirements, since only a radial or axial fan is required to generate the air flow. The fan motors are available in various operating voltages.
- Reduction of noise emissions, since there are no active climate control components mounted on the outside of the enclosure.
- Minimal maintenance required for the fan system.
- Control, monitoring and alarm relays can be achieved via the CMC.

**German utility model no. 210 22 322**

**German patent no. 102 102 10 566**

**US patent no. 6,523,602**

**1** With a radial or axial fan, the hot air from the enclosure is forced into a pipe. A pipeline system laid in the earth cools the air, which in turn is used to cool the enclosure.

**2** In cool external temperatures, the temperature of the air inside the pipeline system rises, and this achieves a heating effect.

**3** **Excellent heat dissipation is effected**, because the pipeline system is laid horizontally on one level. Major excavation work is, however, required.

**4** **The pipeline system is laid vertically**

The pipeline system to and from the outdoor enclosure is laid in a pit. The effects of heat dissipation are somewhat less pronounced, but the pipes are simply laid in a pit where the supply lines to the enclosure can also be laid.

### Terravent supply includes

- Calculation of the maximum required and maximum possible thermal output.
- Calculation and dimensioning of the fan, the pipe diameter, the pipe length, and the best way of laying the pipe.
- Determination of the optimum positioning of the air inlet and air outlet on the enclosure.
- Supply of all components, pre-assembly of the fan pipe fixtures in the outdoor enclosure, installation of the fan, insulation of the enclosure (where necessary).

Packs of	Model No. CS
1 set	9767.500

**Examples of temperature variation,**  
see page 1303.

# CS fuel cell

## Features



Reliable redundancy in the form of emergency power supply systems must be established in critical applications demanding high-availability. From the field of cellular phones via telematics and remote measuring stations through to the primary energy source for information kiosk systems and applications at open-air events – for all these the fuel cell represents the convincing “energy supplier”. Here Rittal with its expertise and know-how in the fields of outdoor enclosure technology, climate control and system integration can supply complete solutions.

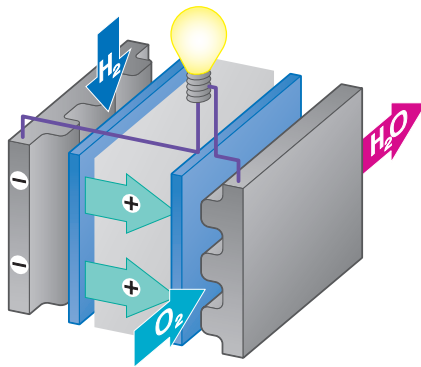

### How a fuel cell works

Fuel cells convert the chemical energy arising from the reaction between hydrogen ( $H_2$ ) and oxygen ( $O_2$ ) directly into electrical energy, water and heat.

- A fuel cell essentially consists of two electrodes separated by an electrolyte.
- At one electrode, the hydrogen is separated into positively charged protons and negatively charged electrons.
- At the other electrode, oxygen molecules ( $O_2$ ) are dissociated (separated) and are able to absorb electrons at the electrode.

- The  $H_2$  ions pass through the electrolyte to the positive electrode where they react with the  $O_2$  ions to form water.
- The two electrodes are connected to one another via an external load so that an electric current flows. The flow of current is supplied directly by converting a significant portion of the chemical energy from hydrogen and oxygen into electrical energy.

### Reliable emergency power supply for outdoor applications

The emergency power supply may be supplied with hydrogen directly at the site of installation.

The oxygen required by the system is obtained from filtered ambient air. The broader temperature range of the fuel cell stacks compared with conventional, battery-buffered back-up systems is a major advantage, since batteries require constant temperatures inside the enclosure.

As a result of this, the fuel cell makes climate control significantly cheaper and more efficient.

#### Other benefits include:

- Freely scalable autonomy, by adapting the volume of hydrogen stored at the site. In this way, individual back-up times may be achieved very easily for each installation site.
- A substantially longer service life than batteries – the total service life of the plant in this mode of operation is approximately 10 years.
- Minimal servicing and maintenance work for the emergency back-up supply.



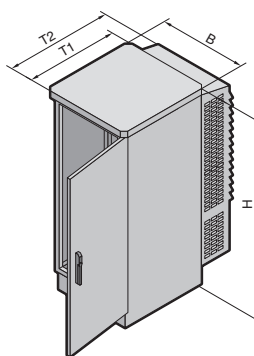

### Application:

Outdoor emergency power supply e. g. for mobile phone base stations.

### Material:

Enclosure frame:  
Stainless steel 1.4301 (AISI 304)  
Doors, side panels, climate control cover, roof:  
Aluminium AlMg3, powder-coated in RAL 7035

### Supply includes:

Ready-to-connect fuel cell system including climate control.  
Hydrogen supply not included.

### Available on request:

- Cascadable up to 3 systems
- Non-standard input/output voltage
- Use as primary supply unit (not for continuous 24 h operation)
- Reformer system, e. g. infeed of methanol instead of hydrogen
- Housing for gas cylinders
- Further protocols:  
S-Bus, Profibus, Modbus, MPI, EIB, LON, BacNet, GENibus

**Detailed drawing,**  
see page 1303.

<b>Width (B) mm</b>	694	694
<b>Height (H) mm</b>	1403	1403
<b>Depth (T1) mm</b>	675	675
Overall depth (T2) mm	992	992
Weight (kg)	219	226
<b>Model No. CS</b>	<b>9782.030</b>	<b>9782.050</b>
<b>Fuel cell</b>		
Output scalable up to	1000 – 3000 W	1000 – 5000 W
Input voltage in standby mode	230 V, 50/60 Hz	230 V, 50/60 Hz
Output voltage	–48 V DC (–42 V DC to –55 V DC)	–48 V DC (–42 V DC to –55 V DC)
<b>Hydrogen supply</b>		
Gas type	Hydrogen, purity at least 3.5 (99.95 %)	Hydrogen, purity at least 3.5 (99.95 %)
Pressurised gas bottles	e. g. 50 litre or 10 litre bottles, 200 bar	e. g. 50 litre or 10 litre bottles, 200 bar
Consumption at full load	45 slpm (standard litres per minute)	75 slpm (standard litres per minute)
Stored energy time	Freely scalable via manifolds, 50 l, 200 bar hydrogen produces approx. 10 kWh output, i. e. with 3 kW full load, this means an autonomy of 3.5 hours	Freely scalable via manifolds, 50 l, 200 bar hydrogen produces approx. 10 kWh output, i. e. with 5 kW full load, this means an autonomy of 2 hours
<b>Ambient conditions</b>		
Temperature range	–40°C to +50°C <sup>1)</sup>	–40°C to +50°C <sup>1)</sup>
Relative humidity	0 % to 95 %, non-condensing	0 % to 95 %, non-condensing
Height above mean sea level	0 to 1800 m	0 to 1800 m
<b>Monitoring</b>		
Interface	Ethernet-IP, RS-232	Ethernet-IP, RS-232

<sup>1)</sup> From 43°C: 2.5 % reduction in output per degree of temperature increase.